

WINSOME WOOD®

Main Office
WINSOME TRADING, INC.
Manufacturers & Distributors
16111 Woodinville-Redmond Road N.E.
Woodinville, WA 98072

Canadian Office
WINSOME TRADING, INC.
Manufacturers & Distributors
108-8116 Alexander Road
Delta, BC V4G 1C6, CANADA

Item No. 81235 Entertainment Cart

Item No. 81235 Chariot de divertissement

Núm. de Artículo 81235 Carrito Para Entretener

Thank you for purchasing one of many Winsome Wood® quality products. Before assembling this unit, please take a moment to read the assembly instructions carefully, and verify the contents of this carton with the check-list table to make sure all parts are included. We would like to hear your comments concerning this product. Please write to the R & D department, 16111 Woodinville-Redmond Rd. N.E., Woodinville, WA 98072-9046.

Care instructions:

Proper care and treatment are essential to preserve the natural beauty of this wood product. To clean wood surfaces, wipe with wet cloth and dry thoroughly. Use mild soap if necessary. Occasional mineral oil treatment will revitalize wood. Use good furniture oil and follow manufacturer's instruction for application. Avoid use of commercial waxes or polishes, glass cleaners or abrasive cleaning materials.

Missing parts request:

To obtain replacement part(s), simply fill in the quantity in the "Missing" column of "Check list/Part replacement request" table, and provide the reason of replacement request. Type or write your name and shipping address clearly, and mail to the address above. Replacements are free of charge with proof of purchase from an authorized dealer and must be claimed within 60 days from date of purchase. Please allow 2-4 weeks for delivery of replacement parts.

Nous vous remercions d'avoir fait l'achat de l'un des nombreux produits de qualité de Winsome Wood®. Avant de procéder à l'assemblage de cette unité, veuillez prendre le temps de lire attentivement les instructions d'assemblage et de vérifier le contenu de ce carton par rapport à la liste d'emballage pour vous assurer que toutes les pièces sont incluses. Nous sommes intéressés à obtenir vos commentaires à propos de ce produit. Veuillez nous écrire au service de recherche, R & D Department, 16111 Woodinville-Redmond Rd. N.E., Woodinville, WA 98072-9046.

Instructions d'entretien:

Il est très important de bien entretenir et de bien traiter ce produit en bois pour en préserver la beauté naturelle. Pour nettoyer les surfaces en bois, essuyez avec un linge humide et séchez à fond. Utilisez un savon doux au besoin. Un traitement occasionnel avec de l'huile minérale revitalisera le bois. Utilisez une bonne huile à meuble et suivez les instructions du fabricant pour l'application. Évitez d'utiliser des cires ou produits à polir de type commercial, des produits pour vitres ou des matériaux de nettoyage abrasifs.

Demande de pièces manquantes:

Pour obtenir une ou des pièces de rechange, veuillez simplement indiquer la quantité dans la colonne «Manquant» du tableau «Liste de vérification/Demande de pièces,» et veuillez avoir la gentillesse de nous fournir la raison pour la demande d'une pièce de rechange. Tapez ou écrivez clairement votre nom et votre d'adresse et envoyez le tout à l'adresse indiquée plus haut. Les pièces de rechange sont gratuites avec preuve d'achat d'un détaillant autorisé et doivent être réclamées dans les 60 jours suivant la date de l'achat. Veuillez compter 2 à 4 semaines pour la livraison des pièces de rechange.

Muchas gracias por haber comprado uno de los tantos productos de calidad de Winsome Wood®. Antes de ensamblar esta unidad, favor de tomarse un momento para leer cuidadosamente las instrucciones de ensamblaje, y verificar el contenido de este cartón con la tabla de la lista de repaso para asegurar que todas las piezas estén incluidas. Le animamos enviar sus comentarios acerca de este producto. Favor de escribir a: R & D Department, 16111 Woodinville-Redmond Rd. N.E., Woodinville, WA 98072-9046.

Instrucciones para el cuidado:

Cuidado y trato apropiado son esenciales para preservar la belleza natural de este producto de madera. Para limpiar las superficies de madera, frótelo con algo húmedo y séquelo bien. Use un jabón suave si es necesario. Un tratamiento ocasional con aceite mineral revitalizará la madera. Use un buen aceite para muebles y siga las instrucciones del fabricante para aplicarlo. Evite el uso de ceras o pulidores comerciales, limpiadores de cristales o materiales abrasivos.

Solicitud de piezas faltantes:

Para obtener el reemplazo de pieza(s) faltante(s), simplemente indique la cantidad en la columna que en Inglés dice "Missing" y "Check-list/Part Request" en la tabla, y provee la razón para el pedido de pieza de reemplazo. Anote claramente su nombre y su dirección y envíelo por correo a la dirección indicada arriba. Los reemplazos son gratuitos con una prueba de compra de un minorista autorizado y tienen que reclamarse dentro de 60 días de la fecha de compra. Por favor permita 2-4 semanas para el entregó de reemplazos.

WINSOME WOOD®

IV/Assembly/AI81235_EntertainmentCart.cdr

© March 2006 Winsome Trading, Inc.

All rights reserved. Printed in Thailand.

Tous droits réservés. Imprimé en Thaïlande.

Todos los derechos están reservados. Impresa en Tailandia.

Main Office

WINSOME TRADING, INC.

Manufacturers & Distributors

16111 Woodinville-Redmond Road N.E.

Woodinville, WA 98072

Canadian Office

WINSOME TRADING, INC.

Manufacturers & Distributors

108-B116 Alexander Road

Delta, BC V4G 1C6, CANADA

Control No.

Check list/Parts request: No. 81235 Entertainment Cart / Chariot de divertissement / Carrito Para Entretener

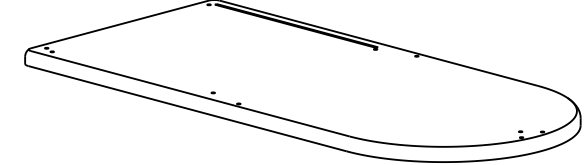
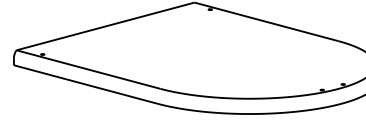
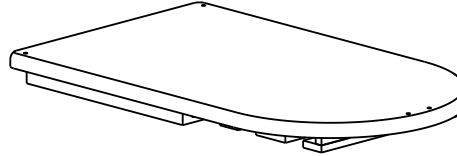
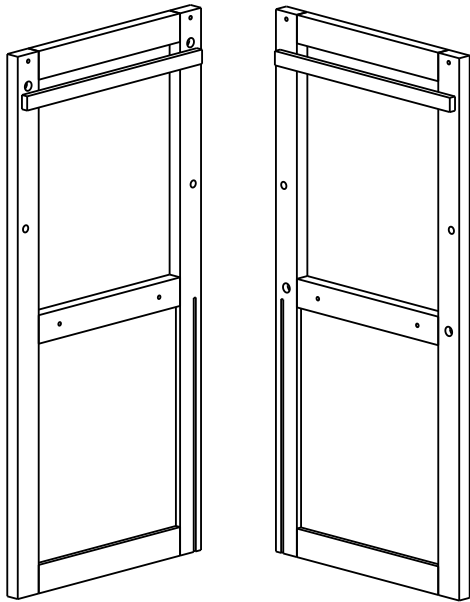

C	Top Dessus Tapa		
Quantity Quantité Cantidad	1	Missing Manquant Ausente	

D	Middle Shelf Tablette centrale Entrepaño de en medio		
Quantity Quantité Cantidad	1	Missing Manquant Ausente	

E	Bottom Shelf Tablette inférieure Entrepaño de abajo		
Quantity Quantité Cantidad	1	Missing Manquant Ausente	

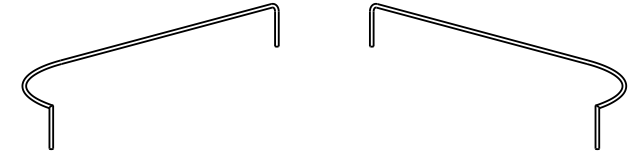
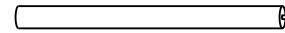
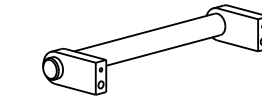

F	Handle Poignée Manija		
Quantity Quantité Cantidad	1	Missing Manquant Ausente	

G	Vertical Support Appui vertical Ayuda vertical		
Quantity Quantité Cantidad	1	Missing Manquant Ausente	

H1	Metal Rail #1 (Long) Barre en métal 1 (longue) Barandal Terminado En Cromo #1 (largo)		
Quantity Quantité Cantidad	1	Missing Manquant Ausente	

H2	Metal Rail #2 (Long) Barre en métal 2 (longue) Barandal Terminado En Cromo #2 (largo)		
Quantity Quantité Cantidad	1	Missing Manquant Ausente	

A	Left Panel Panneau gauche Costado izquierdo		
Quantity Quantité Cantidad	1	Missing Manquant Ausente	

B	Right Panel Panneau droit Costado derecho		
Quantity Quantité Cantidad	1	Missing Manquant Ausente	

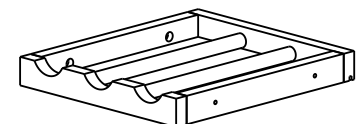
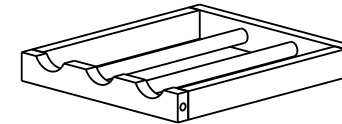
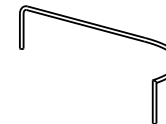
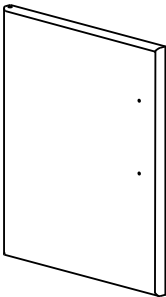

I1	Metal Rail #1 (Short) Barre en métal 1 (courte) Barandal Terminado En Cromo #1 (corto)		
Quantity Quantité Cantidad	2	Missing Manquant Ausente	

I2	Metal Rail #2 (Short) Barre en métal 2 (courte) Barandal Terminado En Cromo #2 (corto)		
Quantity Quantité Cantidad	2	Missing Manquant Ausente	

J	Upper Wine Rack Porte-bouteilles supérieur Estante para vino Superior		
Quantity Quantité Cantidad	1	Missing Manquant Ausente	

K	Lower Wine Rack Porte-bouteilles inférieur Estante para vino de abajo		
Quantity Quantité Cantidad	1	Missing Manquant Ausente	

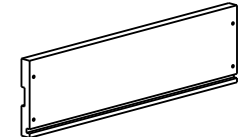
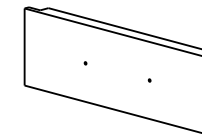
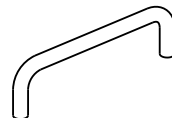

L	Door Porte Puerta		
Quantity Quantité Cantidad	1	Missing Manquant Ausente	

M	Back Panel Panneau arrière Panel Posterior		
Quantity Quantité Cantidad	1	Missing Manquant Ausente	

N	Metal Handle Poignée en métal Manija del metal		
Quantity Quantité Cantidad	2	Missing Manquant Ausente	

O	Magnet Latch Loquet à aimant Pasador magnético		
Quantity Quantité Cantidad	1	Missing Manquant Ausente	

P	Front Panel (Drawer) Panneau avant (tiroir) Panel Delantero (cajón)		
Quantity Quantité Cantidad	1	Missing Manquant Ausente	

Q	Side Panel (Drawer) Panneau latéral (tiroir) Panel Latéral (cajón)		
Quantity Quantité Cantidad	2	Missing Manquant Ausente	

WINSOME WOOD®

IV/Assembly/AI81235_EntertainmentCart.cdr

© March 2006 Winsome Trading, Inc.

All rights reserved. Printed in Thailand.

Tous droits réservés. Imprimé en Thaïlande.

Todos los derechos están reservados. Impresa en Tailandia.

Main Office
WINSOME TRADING, INC.

Manufacturers & Distributors
16111 Woodinville-Redmond Road N.E.
Woodinville, WA 98072

Canadian Office

WINSOME TRADING, INC.
Manufacturers & Distributors
108-8116 Alexander Road
Delta, BC V4G 1C6, CANADA

Control No.

Check list/Parts request: No. 81235 Entertainment Cart / Chariot de divertissement / Carrito Para Entretener

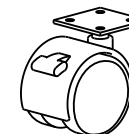
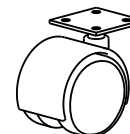
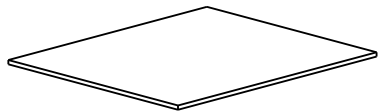

R	Back Panel (Drawer) Panneau arrière (tiroir) Panel posterior (cajon)		
Quantity Quantité Cantidad	1	Missing Manquant Ausente	

S	Bottom Board (Drawer) panneau inférieur (tiroir) Tablero Inferior (cajon)		
Quantity Quantité Cantidad	1	Missing Manquant Ausente	

T	Wood Dowel Goujon en bois Clavija de madera		
Quantity Quantité Cantidad	6	Missing Manquant Ausente	

U1	Wheel Roulette Ruedas		
Quantity Quantité Cantidad	2	Missing Manquant Ausente	

U2	Locking Wheel Roulette à verrouillage Ruedas con cerrójo		
Quantity Quantité Cantidad	2	Missing Manquant Ausente	

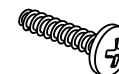
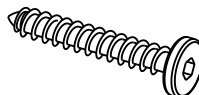
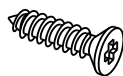
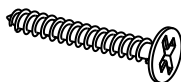

V	Screw (Long) Vis (long) Tornillo (largo)		
Quantity Quantité Cantidad	8	Missing Manquant Ausente	

W	Screw (Small) Vis (petite) Tornillo (pequeño)		
Quantity Quantité Cantidad	18	Missing Manquant Ausente	

X	Wood Screw Vis à bois Tornillo para madera		
Quantity Quantité Cantidad	17	Missing Manquant Ausente	

Y	Bolt Boulon Tornillo de metal		
Quantity Quantité Cantidad	4	Missing Manquant Ausente	

Z	Pivot (door) Pivot (porte) Pivote (puerta)		
Quantity Quantité Cantidad	2	Missing Manquant Ausente	

WINSOME TRADING, INC.

Name/Nom/Nombre

Apartment/Suite No. / N° d'appartement/Num. de Apartamento

Address/Adresse/Dirección

(City/State/Zip) / (Ville/Province/Postal Code)/(Ciudad/Estado/Zona Postal)

Phone/Téléphone/Teléfono: ()

Reason of replacement: / Raison de la demande: / Razón del reemplazo:

Assembly Instructions Instructions d'assemblage Instrucciones de ensamblaje

STEP 1 Drawer / Tiroir / Cajon

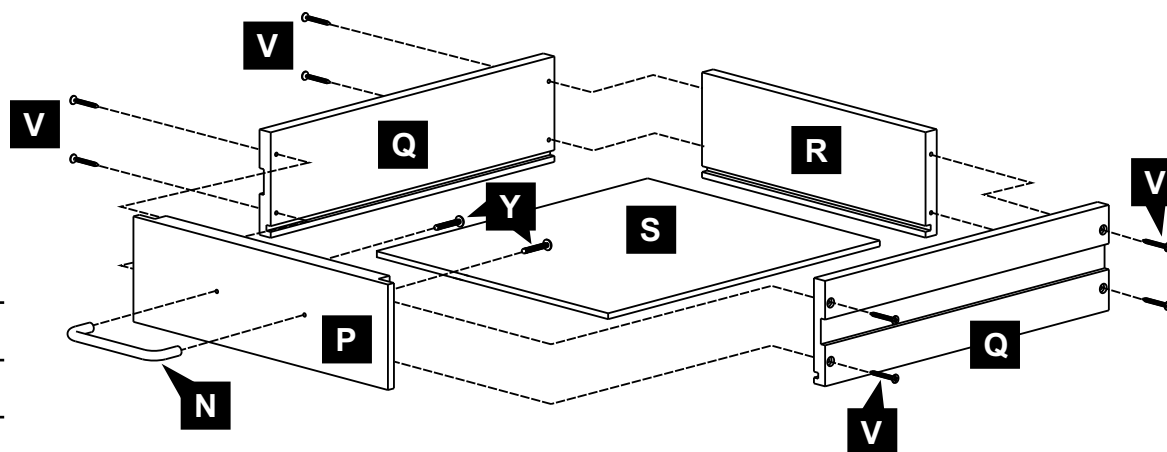

Wrench Clé Llave			
Quantity Quantité Cantidad	1	Missing Manquant Ausente	

STEP 2

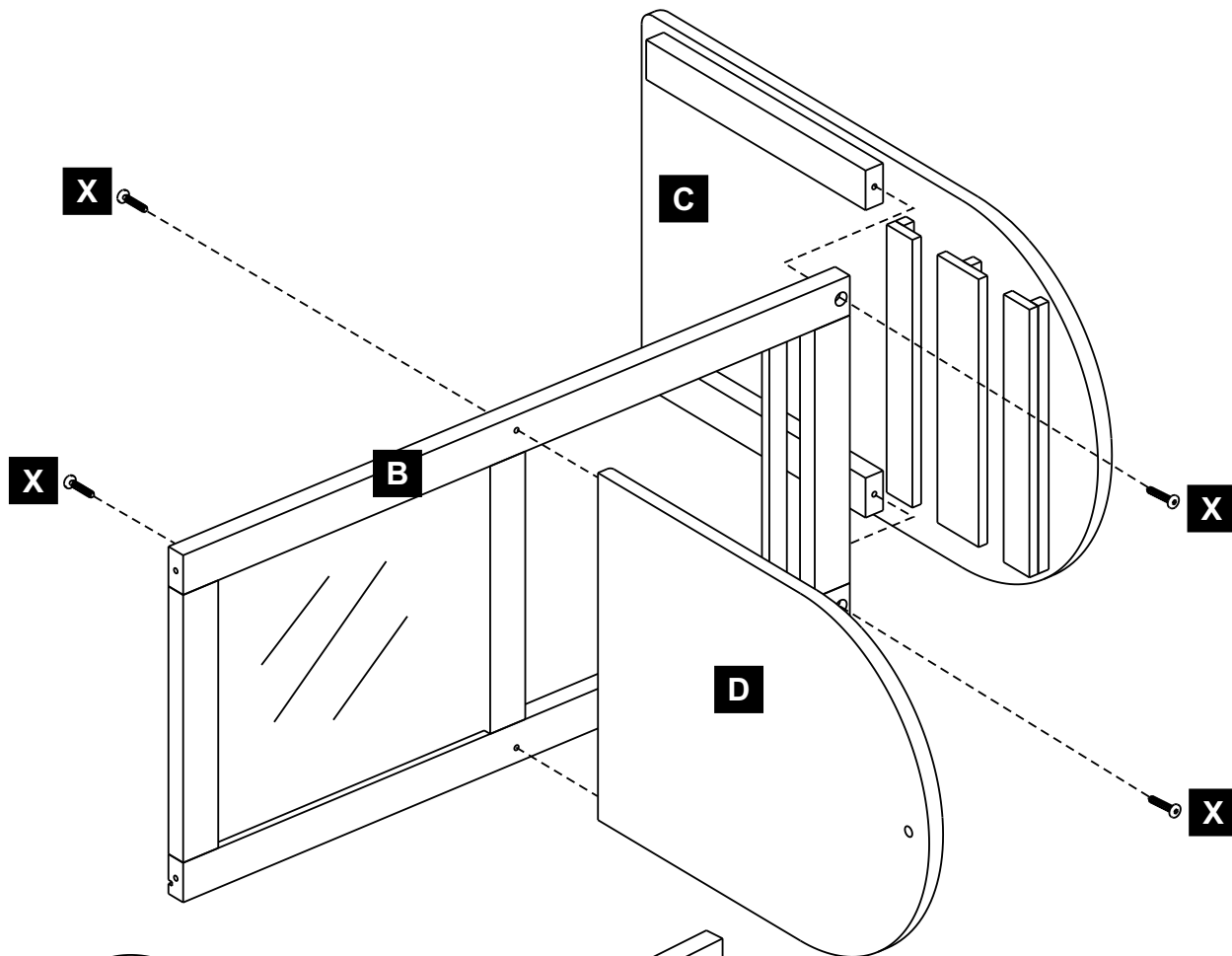

STEP 3

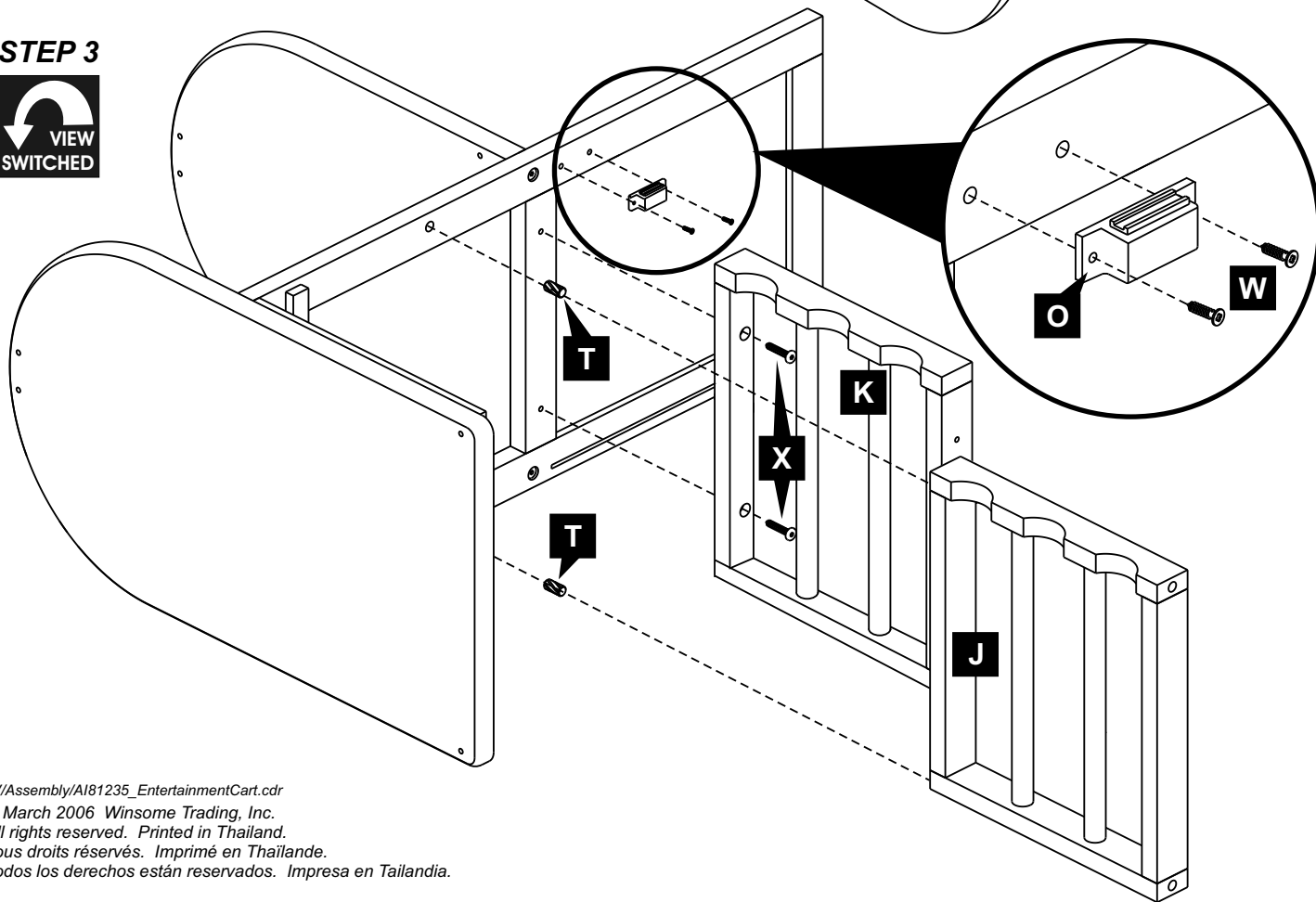

STEP 4

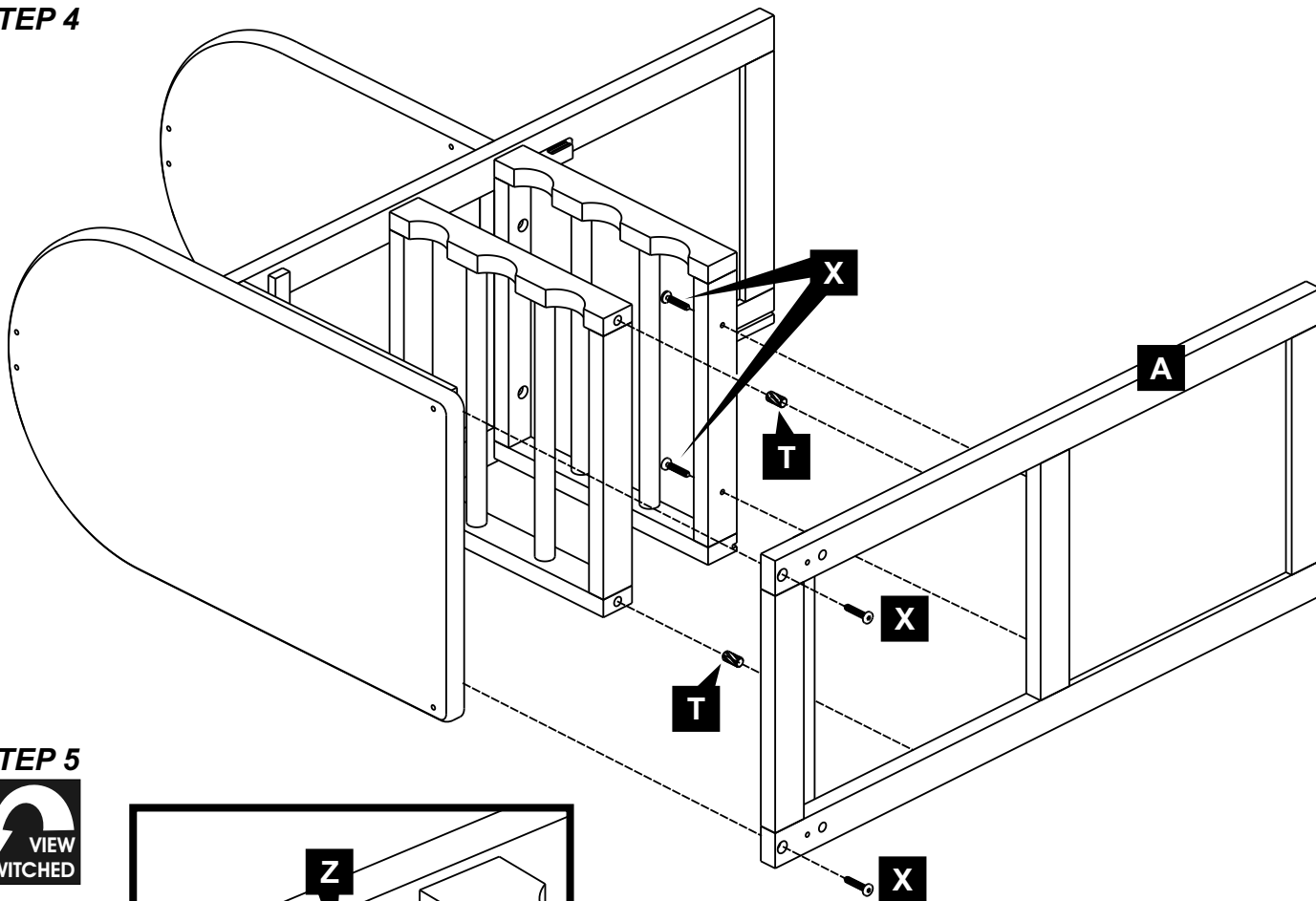

STEP 5

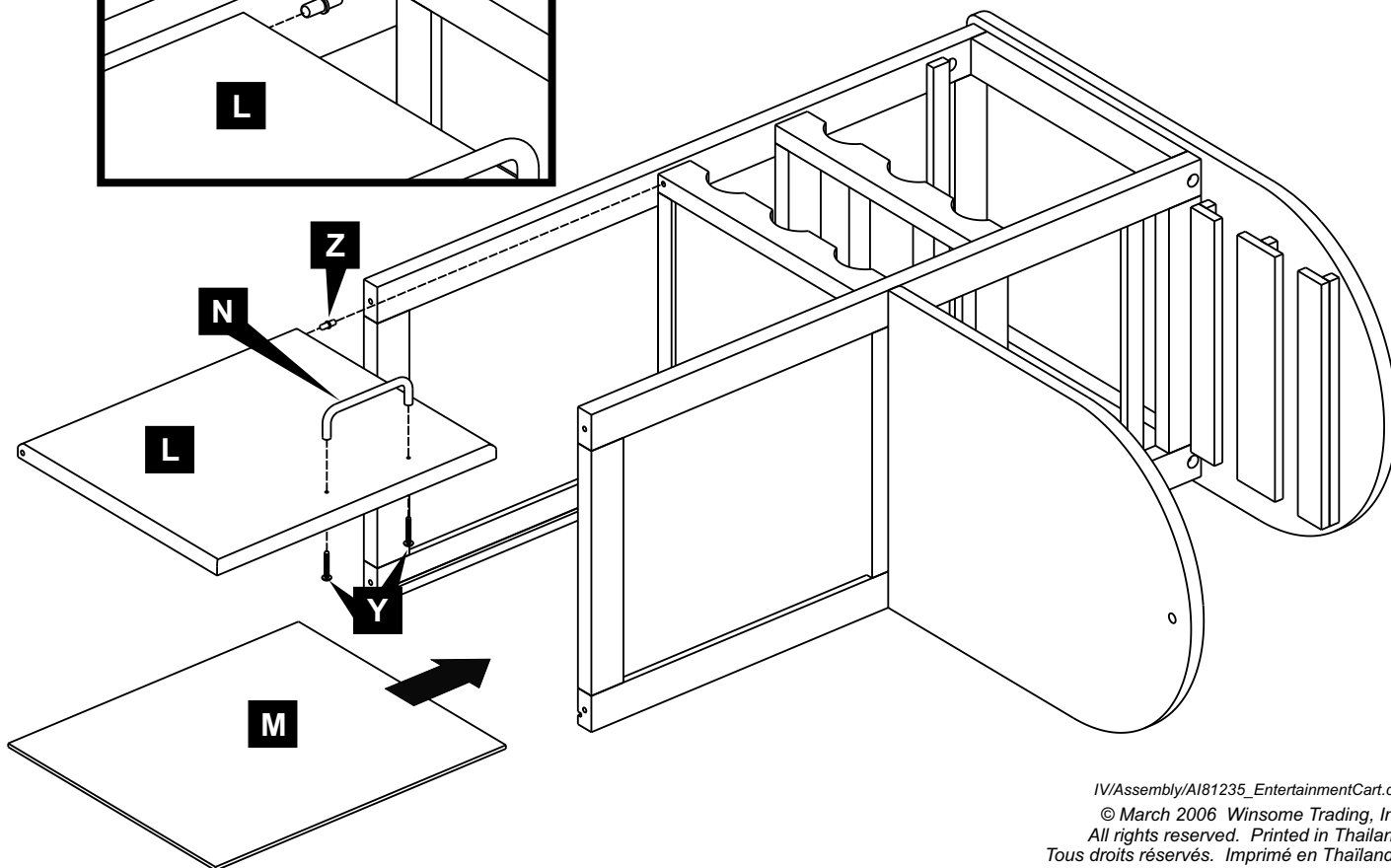
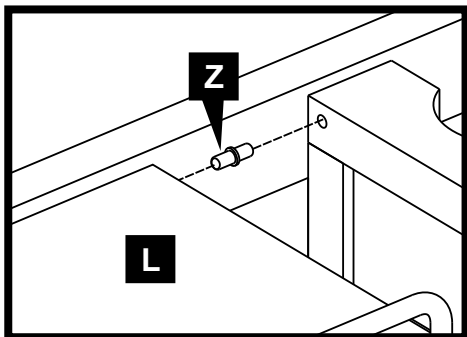

STEP 6

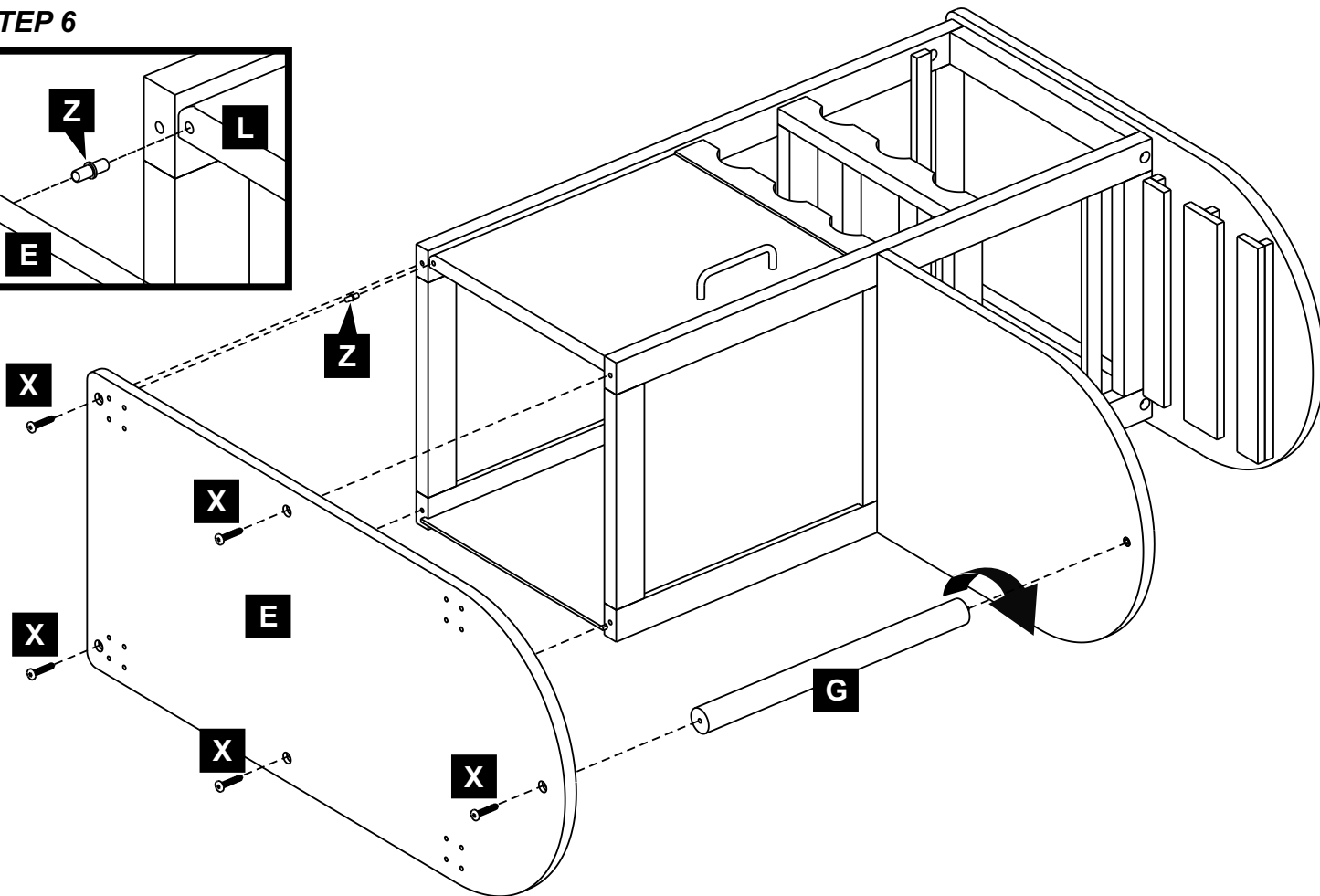
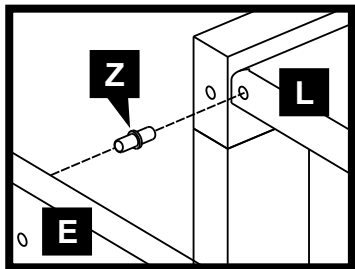

STEP 7

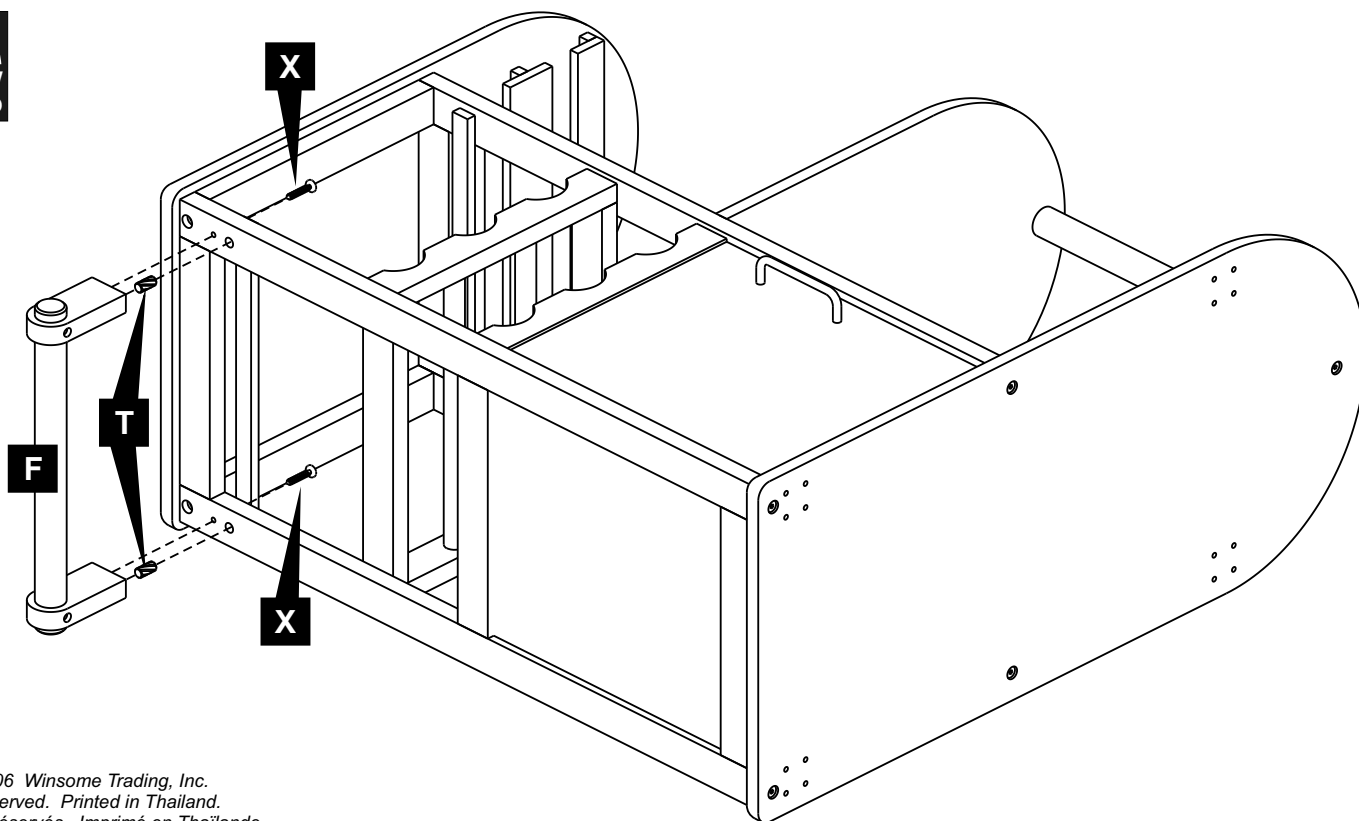

STEP 8

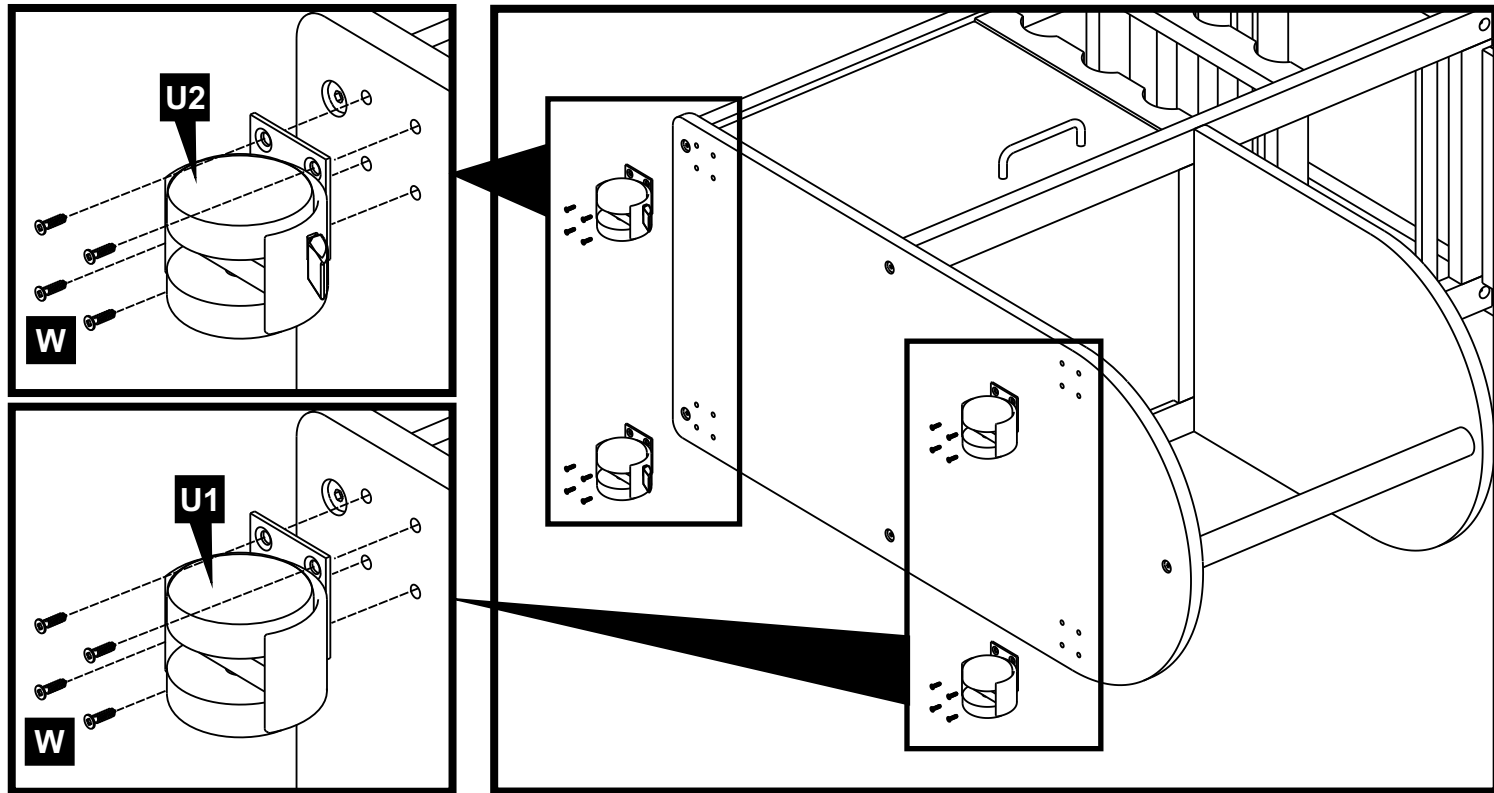

STEP 9

