

# hayneedle

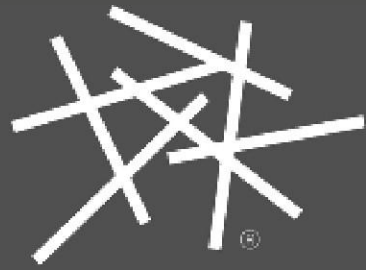

**ITEM NAME:** Foldable Adirondack Chair

**SKU:** MP063



**For assistance with assembly, please contact customer service  
1-888-880-4884**

## PRE-ASSEMBLY PREPARATION:



**DO NOT LET CHILDREN PLAY IN OR AROUND THE UNIT DUE TO THE POSSIBLE RISK OF FINGER ENTRAPMENT**

- Please read through this instruction before beginning assembly.
- Two adults assembly is recommended.
- Clear out the space for assembly and lay out all parts base on Parts List, extra room will allow you to easily determine if all the pieces are present.
- Save all packing materials until assembly is complete to avoid accidentally discarding smaller parts or hardware.
- Keep small parts and pieces away from children until fully assembly.
- Please check for any loose screws and tighten them before you use.

## PANEL AND FITTINGS IDENTIFICATION:

<p>Seat (A) Qty: 1</p>	<p>Back rest (B) Qty: 1</p>	<p>Left and Right Armrest (C) Qty: 2</p>	
<p>Side brackets (D) Qty: 2</p>	<p>Front legs (E) Qty: 2</p>	<p>Front leg connection beam (F) Qty: 1</p>	<p>Rear seat slat (G) Qty: 1</p>

## HARDWARE LIST:

<p>Screw 4x30 Stainless Steel (1) Qty: 2</p>	<p>Screw 4x30 Galvanized Steel (2) Qty: 4</p>	<p>Bolt M 8x35 (3) Qty: 10</p>
--	---	--------------------------------

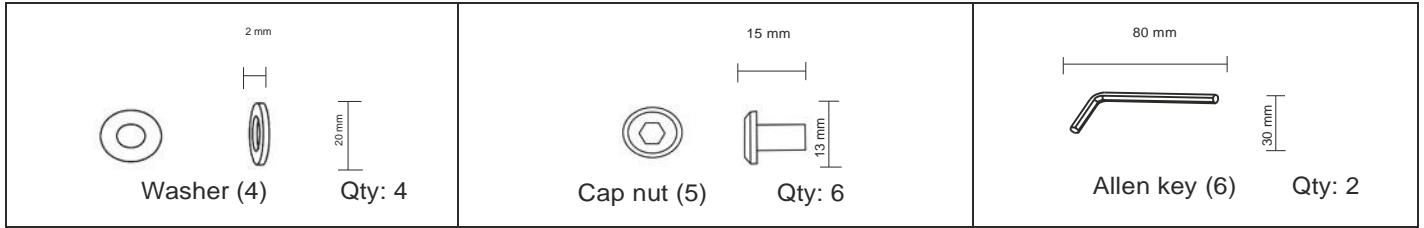

## Philips Screwdriver

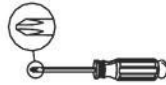

**Notes:** Do not completely tighten any bolts and screws until the units is fully assembled and set on a level surface.

### STEP-BY-STEP ASSEMBLY:

1

**STEP 1:** Attach the Rear seat slat (G) into the Seat (A) with screw (1) using the Screwdriver

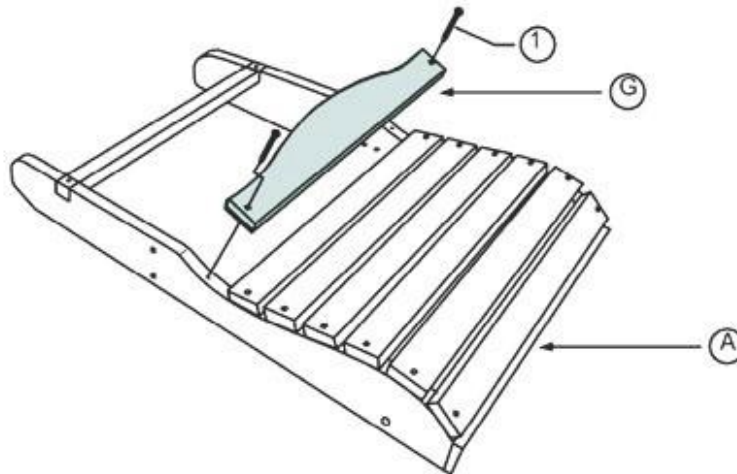

2

**STEP 2:** Fasten the 2 Front legs (E) into the Seat (A) with Bolt (3), Washer (4) and Cap nut (5) using the Allen key (6).

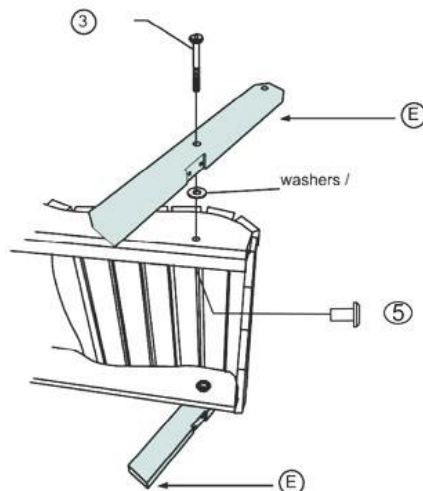

3

**STEP 3:** Put the Front leg connection beam (F) into the two Front legs (E). Fasten with Screw (2) using the Screwdriver.

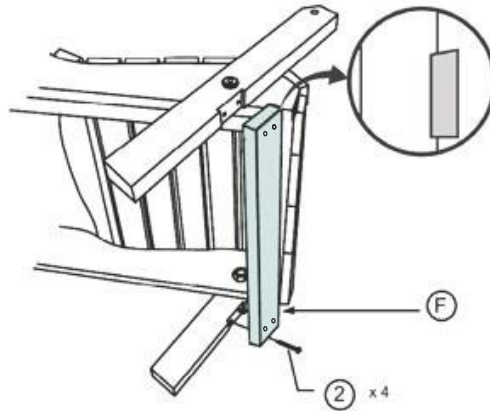

4

**STEP 4:** Fasten the Back rest (B) and two the Side Brackets (D) into the Front leg (1) using Bolt (3), washer (4) and Cap nut (5) using the Allen key (G).

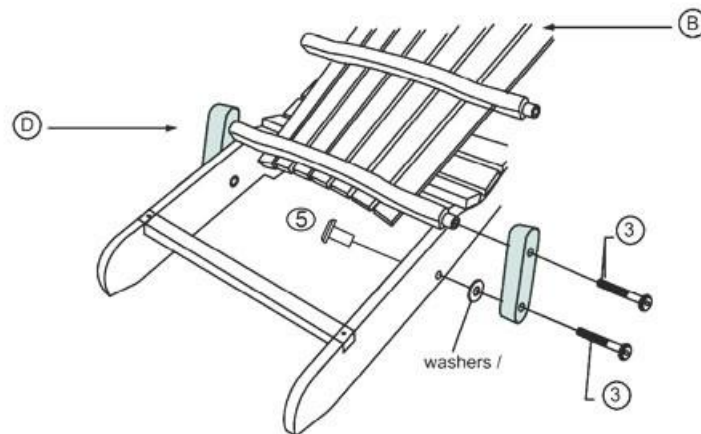

5

**STEP 5:** Attach the left and right armrest (C) in points the two Front legs and Back rest (B) with bolt (3), Washer (4), and Cap nut (5) using the Allen key (G).

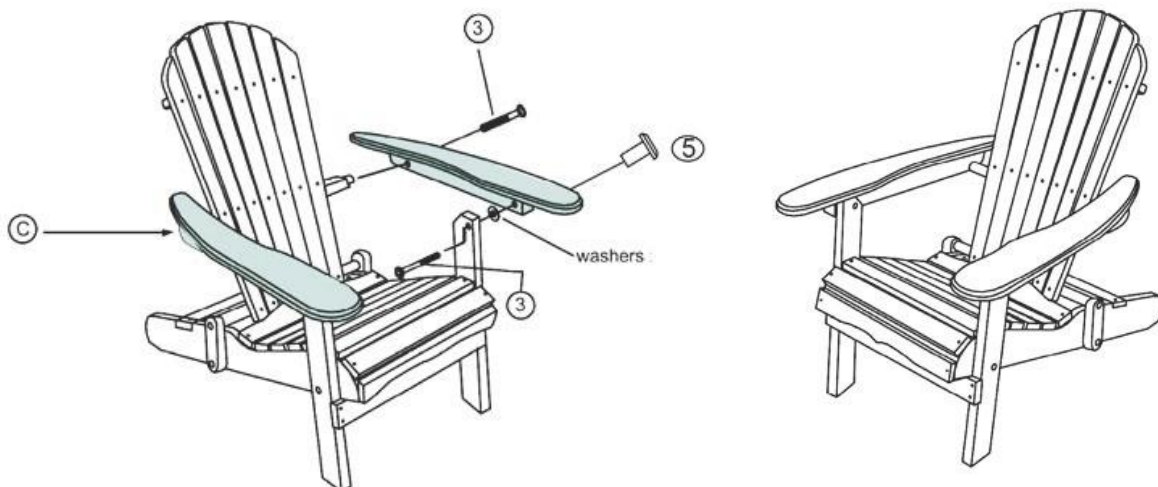

## MAINTENANCE AND CARE TIPS FOR OUTDOOR WOOD FURNITURE

The best way to preserve and extend the life of your outdoor wood furniture is to cover it with a waterproof cover when it's not in use, store it in a cool, dry place like a garage or shed during the winter months, and keep the wood hydrated with products like linseed oil a couple times per year. The less exposure your wood furniture has to sun, wind, rain, and snow, the longer it will last. Woods that are stained or painted should be sanded and re-stained or repainted as needed to protect the elements from penetrating the surface. Wood left in direct contact with wet surfaces will quickly become saturated and rot. When wood does get wet, dry it off as quickly as possible.

It's also important to place your outdoor wood furniture on a surface where water won't pool. A patio or deck is an ideal spot, and you should consider paving stones or a bed of rocks for wood furniture out in the garden. Wood left in direct contact with wet surfaces will quickly become saturated and rot. When wood does get wet, dry it off as quickly as possible or leave it out in the sun to dry.

Frequently exposed to harsh conditions or damp surfaces, wood furniture will begin to show signs of wear and deterioration. Signs of damage may include checking (cracking or splitting), swelling, rotting, and discoloration. In addition to protective covers and off-season storage, you can further prevent this type of damage by keeping woods well-hydrated with products like linseed oil. Saturate your furniture with the oil several times per year. Well-oiled wood will be better-protected from the elements and will retain its color and smooth surface longer. Woods that are stained or painted should be sanded and re-stained or repainted as needed to protect the elements from penetrating the surface.

Take time to learn more about how your particular type of wood tends to weather. Some woods, like pine, will require frequent staining or oiling, while a wood like cedar has natural oils that make it resistant to cracking and moisture rot. Woods like teak will turn a silver grey when left untreated, and many outdoor wood furniture owners look forward to this transformation.

Finally, dirt build-up leads to deterioration, so keeping your outdoor wood furniture clean will give it a longer life. Clean it well two or three times per year with water, mild soap, and a soft cloth. (This is also the perfect time for a periodic hardware check.) We recommend using a product specifically designed for cleaning wood furniture. Hose it down before you start to remove cobwebs and caked-on dirt. Do not use abrasive cleaners, bleach, or scouring products that will affect the finish. Dry the furniture thoroughly when done. Poolside furniture should be hosed down after each use to minimize chlorine damage.